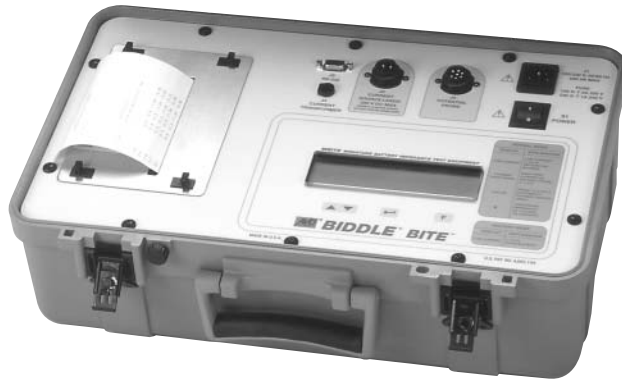

MBITE**Miniature Battery Impedance Test Equipment**

- **Determines condition of lead-acid and NiCd batteries on-line to 2500 Ah**
- **Helps to ensure (Improves) critical equipment back-up and (continuous) revenue streams**
- **Directly measures intercell connection resistance and voltage**
- **Standard and Custom Lead Sets available**
- **17% smaller than the previous version**

DESCRIPTION

The Miniature Battery Impedance Test Equipment, MBITE, is designed and ideally suited to determine the health of flooded and sealed lead-acid and Ni-Cd batteries in telecomm, RR signal and communications, substation, process control and switchgear, emergency lighting systems, smaller UPSs, and more. An additional application is to measure impedance of batteries at the end of the production line in battery manufacturing plants.

The MBITE is a lightweight, easy-to-use battery tester that incorporates advanced features for enhanced capabilities to provide fast, reliable results to determine what further action may be required to ensure adequate system back-up time. After all, measuring batteries is not for the battery but for the equipment the battery is supporting whether to ensure revenue streams or to support critical plant equipment such as oil priming pumps.

In addition to measuring battery impedance and interconnection resistance, the MBITE also measures individual dc terminal voltages. Furthermore, since impedance does not stress the battery, terminal voltages may be used when they need to be documented. All three parameters can be stored (up to 1000 lines of readings) on-board for immediate review at the test site on the large 3 1/2 digit LCD or from the built-in printer. The stored data also can be downloaded via the RS-232 connector to a PC using "AVOLink" download software or other conventional communications packages to spreadsheet applications for further data interpretation. The Battery Analysis Report (see Figure 1) prints out cell number, battery impedance, interconnection resistance,

cell dc voltage, date and time at which cell impedance is recorded, total test current, and cell impedance summary including graphical analysis. The printed header has space to record user, location and cell IDs using the Bar Code Wand listed in **Optional Accessories**.

Battery Analysis Report						
Location ID: USA Mobile Comm Site 37W Str 1A						
User ID: John Doe						
Average Test Current: 0.98						
Notes: _____						

23-FEB-2000						
TST	Cell	Zb mΩ	RS mΩ	Volts DC	Time	
001	1A01	2.46	0.356	6.18	10:56	
002	1A02	2.34	0.359	6.23	10:57	
003	1A03	2.65	0.341	6.23	10:57	
004	1A04	2.47	0.355	6.18	10:58	
005	1A05	2.34	0.337	6.23	10:58	
006	1A06	2.65	0.347	6.23	10:58	
Cell Impedance Summary						
Minimum		Average		Maximum		
2.34		2.48		2.65		
Percent Deviation from Average						
	-10	0	10	20	30	
001						
002						
003						
004						
005						
006						

Figure 1. The Battery Analysis Report (with Loc ID, User ID, Notes, Cell ID filled-in)

Unlike load cycle testing, which involves substantial downtime and performed periodically, the MBITE requires no battery discharge. With a test time of less than 30 seconds per cell, it measures internal cell impedance, dc terminal voltage and intercell connection resistance without taking batteries off-line. The MBITE, like the original BITE, is used to find weak cells due to sulphation, post-seal corrosion, and poor top lead and intercell connections. The test results, along with user-supplied information such as ambient temperature and system ac ripple current, will provide sufficient information to evaluate the overall battery system.

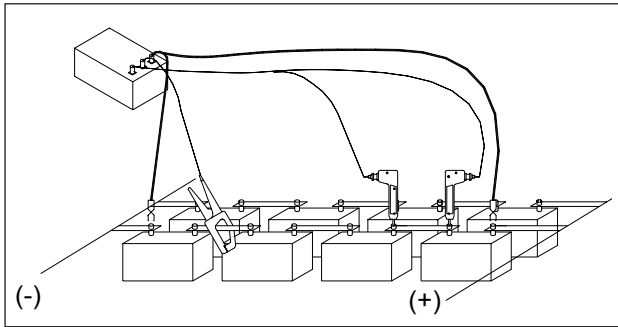

Figure 2. A typical test set-up.

Why Measure Batteries at all?

Measuring batteries is not for the battery but for the equipment the battery is supporting whether to ensure revenue streams as in wireless phone service or to support critical plant equipment such as oil priming pumps. In a sense, it is insurance that the MBITE provides and peace-of-mind knowing that the batteries are in good health.

APPLICATIONS

The MBITE measures impedance values and dc voltage for flooded and sealed lead-acid and nickel-cadmium cells. This information aids the operator to determine cell replacement criteria based on impedance trends. The MBITE also identifies weak cells in a battery string and pinpoints unsatisfactory intercell and/or intertier connections. A schematic diagram of a typical test setup is shown in Figure 2.

Test Procedure

The MBITE base measurement unit applies a capacitively coupled ac current to the battery under test by way of the current source leads. Current sensors monitor source current. The standard CT has a 2-in. (50-mm) internal dimension while the optional CT is 0.5 in. (13 mm). The CT is clamped around a convenient battery intercell or intertier connection within the battery's current loop. The potential probes are placed across the cell under test. The base measurement unit displays cell impedance and dc float voltage as well as intercell connection resistance. Figure 3 shows the value of taking direct intercell connection resistance measurements. The information can be verified by the operator and then stored by pressing the data send button on the potential probe before moving onto the next cell. Intercell resistance measurements also

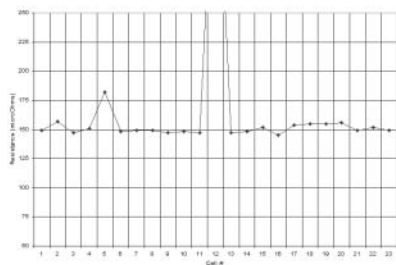

Figure 3. Intercell Connection Resistance.

can be made and stored using the cell/strap mode. Single cell/module applications can be accommodated using one of the optional Factory Probe Lead Sets.

Interpretation of Readings

Data produced by the MBITE can be interpreted in both short- and long-term time frames. It is recommended that MBITE measurements be made part of a battery

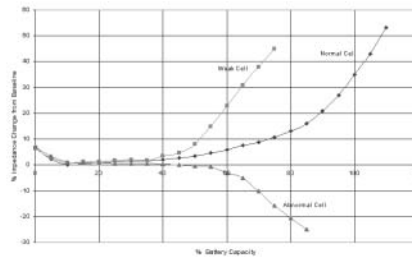

Figure 4. Impedance increases with battery age (and weakness.)

maintenance program, with readings taken and recorded quarterly or semi-annually. Figure 4 shows an example of how impedance changes as cells weaken over time and cycle life.

Short Term Interpretation

Impedance readings for individual cells can be used in the short term to compare with the average impedance reading for the entire battery. Individual cell values varying by more than $\pm 40\%$ of the (sealed) battery average typically indicate a problem with that cell (and $\pm 20\%$ for flooded). There are two different methods of evaluating impedance data in Excel®: 1) use the bar graph of the MBITE printout in Cell # order and 2) by rearranging the data into ascending impedance as shown in Figure 5 using a spreadsheet. The cells on the right side of the graph are weaker than the others. The dramatic increase in impedance is a clear indication of questionable cells. Further investigation of such cells is recommended,

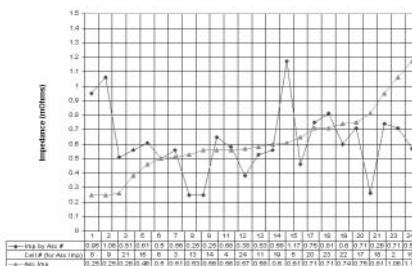

Figure 5. Ascending Impedance.

including a verification of intercell connections, specific gravity, if appropriate, ambient temperature, and perhaps, a single cell load-cycle test.

Long-Term Interpretation

Impedance readings can be used in the long term to determine replacement criteria. Battery cell impedance values should be recorded and compared to previous

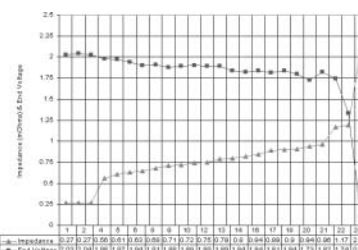

Figure 6. Ascending Impedance compared to Load Test,

readings to determine the cell's position on the curve of impedance versus cell life. Individual cell values varying by more than $\pm 40\%$ from the initial baseline of the battery average typically indicate a problem with that cell (and $\pm 20\%$ for

flooded). A sample curve is shown in Figure 4. In order to facilitate the long-term interpretation of impedance values, Megger maintains a database of impedance values of many battery types. For comparison purposes, this information is available upon request.

An additional data evaluation method that can be used in either a short-term or a long-term mode is in conjunction with load test data. By taking impedance measurements just prior to a load test and comparing them with end voltage, a correlation between impedance and that string's capacity can be derived. See Figure 6.

FEATURES AND BENEFITS

- Provides excellent data to evaluate critical systems' back-up time
- On-line testing requires no downtime
- Graphical printout aids to quickly determine cell/jar condition to make immediate decisions
- Data is stored for on-site review
- Requires no battery discharge to save cycle life
- Built-in printer to leave a record at the site
- RS-232 connector for downloading stored data to PC
- Reduced testing time; less than 30 seconds per cell
- Measures impedance and dc cell voltage for lead-acid and nickel-cadmium cells
- Directly measures intercell connection resistance to eliminate routine retortiquing
- Up to 1000 sets of readings can be stored in an unlimited number of tests
- Custom Lead Sets available to meet specific needs

SPECIFICATIONS

Maximum Total Voltage at MBITE Leads

250 V dc. Larger battery systems can be sectioned

Power Requirements

120 V ac 60 Hz (240 V ac 50 Hz on -47 and -47-CE models)

Display

Backlit LCD panel with 5-in. (125 mm) viewing area

Voltage Range

0 to 2.500 V dc, 1 mV resolution
2.5 to 25.00 V dc, 10 mV resolution

Impedance Range

0 to 1.000 mΩ 1 μΩ resolution
1 to 10.00 mΩ 10 μΩ resolution

Measurement Accuracy

AC impedance: ±(5% rdng + 1 lsd)

DC voltage: ±(1% rdng + 1 lsd)

Settling Time per Reading

3 seconds maximum

Temperature

Operating: 32° F to 104° F (0° C to 40° C)

Storage: -5° F to 130° F (-20° C to 55° C)

Humidity: 20% to 90% RH, non-condensing

Clamp Range

Standard Opening: 2.0 in. (50 mm) maximum

Optional Opening: 0.5 in. (12 mm) maximum

Safety

Designed to meet IEC 1010-1 specifications

Dimensions: 7H x 11D x 17W in. (18 H x 29 D x 45 W cm)

Weight: 19.5 lbs. (8.8 kg)

ORDERING INFORMATION

Item (Qty)	Cat. No.
MBITE, 110/60	246005B
MBITE, 240/50	246005B-47
MBITE, 240/50, CE-marked	246005B-47-CE
Included Accessories	
Potential Probe set	33530
Potential Probe cable (8 ft.)	33806
Fused Current Source Leads (8 ft.)	33805
Clamp-on current sensor, CT, with 1/2 in. opening (5 ft.)	33863
Extension cable, CT (6 ft.)	33864-1
AVOLink, downloading software Instruction manual	AVTM246005B
Optional Accessories	
Potential Probe extension cable (8 ft.)	33806
Extension cable, CT (20 ft.)	246033
Clamp-on current sensor, CT, with 1/2 in. opening	246034
Factory Probes, dual-point helical hand spikes	33532
Factory Probes, AMP/Burndy Lead Set	33531
Bar Code wand with preprinted, laminated code sheet	246036
Bar Code Label printing software	246039